

# R-XPT-HD Hot Dip Galvanized Throughbolt

Hot Dip Galvanized throughbolt for non-cracked concrete



## Product information

### Features and benefits

- Increased corrosion resistance due to hot dip zinc external protection layer
- R-XPT is suitable for reduced embedment to avoid contact with reinforcement
- Embedment depth markings help to ensure precise installation of the anchor
- Design of R-XPTII allows drilling and installing directly through the fixture and helps to reduce installation time
- High quality with cost effectiveness
- Cold formed body ensures consistent dimensional accuracy

### Applications

- Cladding restraint
- Curtain wall
- Balustrading
- Barriers
- Handrails
- Racking
- Structural steel
- Bollards

### Base materials

**Approved for use in:**

- Non-cracked concrete C20/25-C50/60
- Unreinforced concrete
- Reinforced concrete

**Also suitable for use in:**

- Natural Stone

## Installation guide



1. Drill a hole of required diameter and depth
2. Clear the hole of drilling dust and debris (using blowpump or equivalent method)
3. Lightly tap the throughbolt through the fixture into hole with a hammer, until fixing depth is reached
4. Tighten to the recommended torque

**Product information**

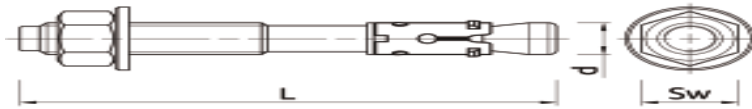

Size	Product Code	Anchor		Fixture		
		Diameter	Length	Max. thickness	Max. thickness $t_{fix}$ for:	Hole diameter
		d [mm]	L [mm]	$t_{fix,r}$ [mm]	$h_{nom,std}$ [mm]	$d_f$ [mm]
M6	R-XPT-HD-06050/10	6	50	10	-	7
	R-XPT-HD-06085/25	6	85	45	25	7
	R-XPT-HD-06100/40	6	100	60	40	7
M8	R-XPT-HD-08050/5	8	50	5	-	9
	R-XPT-HD-08060/10	8	60	10	-	9
	R-XPT-HD-08065/15	8	65	15	-	9
	R-XPT-HD-08075/10	8	75	25	10	9
	R-XPT-HD-08080/15	8	80	30	15	9
	R-XPT-HD-08095/30	8	95	45	30	9
	R-XPT-HD-08115/50	8	115	65	50	9
	R-XPT-HD-08140/75	8	140	90	75	9
	M10	R-XPT-HD-10065/5	10	65	5	-
R-XPT-HD-10080/10		10	80	20	10	11
R-XPT-HD-10095/25		10	95	35	25	11
R-XPT-HD-10115/45		10	115	55	45	11
R-XPT-HD-10130/60		10	130	70	60	11
R-XPT-HD-10140/70		10	140	80	70	11
M12	R-XPT-HD-12080/5	12	80	5	-	13
	R-XPT-HD-12100/5	12	100	25	5	13
	R-XPT-HD-12120/25	12	120	45	25	13
	R-XPT-HD-12125/30	12	125	50	30	13
	R-XPT-HD-12135/40	12	135	60	40	13
	R-XPT-HD-12150/55	12	150	75	55	13
	R-XPT-HD-12180/85	12	180	105	85	13
	R-XPT-HD-12220/125	12	220	145	125	13
M16	R-XPT-HD-16100/5	16	100	5	-	18
	R-XPT-HD-16105/10	16	105	10	-	18
	R-XPT-HD-16125/5	16	125	25	5	18
	R-XPT-HD-16140/20	16	140	40	20	18
	R-XPT-HD-16150/30	16	150	50	30	18
	R-XPT-HD-16160/40	16	160	60	40	18
	R-XPT-HD-16180/60	16	180	80	60	18
	R-XPT-HD-16220/100	16	220	120	100	18
M20	R-XPT-HD-20125/5	20	125	5	-	22
	R-XPT-HD-20160/20	20	160	40	20	22
	R-XPT-HD-20200/80	20	200	80	60	22
M24	R-XPT-HD-24260/100	24	260	115	100	26

## Installation data

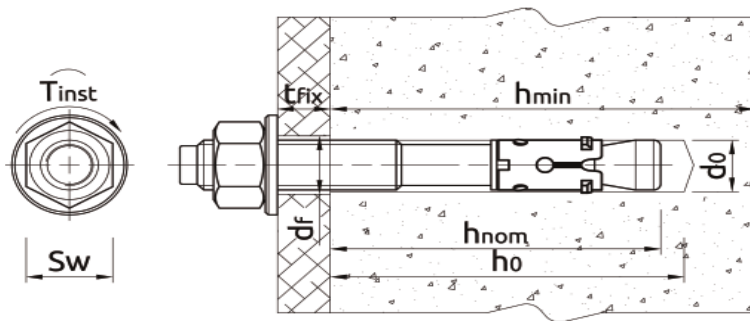

Size			M6	M8	M10	M12	M16	M20	M24
Thread diameter	d	[mm]	6	8	10	12	16	20	24
Hole diameter in substrate	d <sub>0</sub>	[mm]	6	8	10	12	16	20	24
Installation torque	T <sub>inst</sub>	[Nm]	5	15	30	50	100	200	300
Wrench size	Sw	[mm]	10	13	17	19	24	30	36
<b>STANDARD EMBEDMENT DEPTH</b>									
Min. hole depth in substrate	h <sub>0,s</sub>	[mm]	55	60	65	85	105	125	140
Installation depth	h <sub>nom,s</sub>	[mm]	50	55	59	80	100	119	135
Min. substrate thickness	h <sub>min,s</sub>	[mm]	84	100	100	136	170	198	224
Min. spacing	s <sub>min,s</sub>	[mm]	45	50	55	75	90	140	180
Min. edge distance	c <sub>min,s</sub>	[mm]	50	40	50	65	80	100	200
<b>REDUCED EMBEDMENT DEPTH</b>									
Min. hole depth in substrate	h <sub>0,r</sub>	[mm]	35	45	55	65	85	105	125
Installation depth	h <sub>nom,r</sub>	[mm]	30	40	49	60	80	99	120
Min. substrate thickness	h <sub>min,r</sub>	[mm]	80	100	100	100	130	158	194
Min. spacing	s <sub>min,r</sub>	[mm]	40	45	55	100	100	125	160
Min. edge distance	c <sub>min,r</sub>	[mm]	45	40	65	100	100	125	160

## Mechanical properties

Size			M6	M8	M10	M12	M16	M20	M24
Nominal ultimate tensile strength - tension	f <sub>uk</sub>	[N/mm <sup>2</sup> ]	400	400	400	400	400	480	480
Nominal ultimate tensile strength - shear	f <sub>uk</sub>	[N/mm <sup>2</sup> ]	520	520	520	520	520	520	680
Nominal yield strength - tension	f <sub>yk</sub>	[N/mm <sup>2</sup> ]	539	531	531	531	531	531	496
Nominal yield strength - shear	f <sub>yk</sub>	[N/mm <sup>2</sup> ]	416	416	416	416	416	416	544
Cross sectional area - tension	A <sub>s</sub>	[mm <sup>2</sup> ]	15.2	25.5	40.7	60.1	106.6	162.9	311
Cross sectional area - shear	A <sub>s</sub>	[mm <sup>2</sup> ]	20.1	36.6	58	84.3	157	245	353
Elastic section modulus	W <sub>el</sub>	[mm <sup>3</sup> ]	12.7	31.2	62.3	109.2	277.5	540.9	935.5
Characteristic bending resistance	M <sup>0</sup> <sub>Rk,s</sub>	[Nm]	7.1	17	35	61	155	302	651
Design bending resistance	M	[Nm]	5.7	14	28	49	124	241	521

## Basic performance data

Performance data for single anchor without influence of edge distance and spacing

Size		M6	M8	M10	M12	M16	M20	M24
<b>MEAN ULTIMATE LOAD</b>								
<b>TENSION LOAD N<sub>Ru,m</sub></b>								
Standard embedment depth	[kN]	8.68	16.15	20.03	29.95	47.87	58.40	71.73
Reduced embedment depth	[kN]	4.20	9.61	12.91	20.95	34.75	46.60	61.57
<b>SHEAR LOAD V<sub>Ru,m</sub></b>								
Standard embedment depth	[kN]	6.66	12.15	19.24	27.95	51.54	80.85	152.33
Reduced embedment depth	[kN]	6.66	12.15	16.00	27.95	51.54	80.85	152.33

## Basic performance data

## Design performance data

Standard embedment depth

Size			M6	M8	M10	M12	M16	M20	M24
Effective embedment depth	$h_{ef}$	[mm]	42.00	47.00	49.00	68.00	85.00	99.00	112.00
<b>TENSION LOAD</b>									
<b>STEEL FAILURE</b>									
Characteristic resistance	$N_{Rk,s}$	[kN]	9.58	15.80	25.20	37.30	66.10	101.00	180.39
Design resistance $V_{Ms} = 1.4$	$N_{Rd,s}$	[kN]	6.84	11.29	18.00	26.64	47.21	72.14	128.85
<b>PULL-OUT FAILURE; NON-CRACKED CONCRETE C20/25</b>									
Characteristic resistance	$N_{Rk,p}$	[kN]	6.85	9.72	12.61	20.17	27.59	35.02	41.89
Design resistance $V_{Mp} = 2.52$	$N_{Rd,p}$	[kN]	2.72	3.86	5.00	8.00	10.95	13.90	16.62
Increasing factors for $N_{Rd,p} - C30/37$	$\Psi_c$	-	1.00	1.00	1.00	1.00	1.00	1.00	1.00
Increasing factors for $N_{Rd,p} - C40/50$	$\Psi_c$	-	1.00	1.00	1.00	1.00	1.00	1.00	1.00
Increasing factors for $N_{Rd,p} - C50/60$	$\Psi_c$	-	1.00	1.00	1.00	1.00	1.00	1.00	1.00
Spacing	$s_{cr,N}$	[mm]	126.00	141.00	147.00	204.00	255.00	297.00	336.00
Edge distance	$c_{cr,N}$	[mm]	63.00	71.00	74.00	102.00	128.00	149.00	168.00
<b>SHEAR LOAD</b>									
<b>CONCRETE EDGE FAILURE; NON-CRACKED CONCRETE C20/25</b>									
Edge distance	$c_1$	[mm]	50.00	40.00	50.00	65.00	80.00	100.00	200.00
Characteristic resistance for $c_1$	$V_{Rk,c}$	[kN]	6.39	5.03	7.07	10.96	15.77	22.56	58.63
Design resistance $V_{Mc} = 1.8$	$V_{Rd,c}$	[kN]	3.55	2.79	3.93	6.09	8.76	12.53	32.57
<b>CONCRETE PRY-OUT FAILURE; NON-CRACKED CONCRETE C20/25</b>									
	$k$	-	1.00	1.00	1.00	2.00	2.00	2.00	2.00
Characteristic resistance	$V_{Rk,cp}$	[kN]	6.85	9.72	12.61	40.34	55.18	70.04	83.78
Design resistance $V_{Mc} = 2.52$	$V_{Rd,cp}$	[kN]	2.72	3.86	5.00	16.01	21.90	27.79	33.25
<b>STEEL FAILURE</b>									
Characteristic resistance without lever arm	$V_{Rk,s}$	[kN]	5.50	10.10	16.00	23.30	43.00	67.40	126.94
Design resistance $V_{Ms} = 1.25$	$V_{Rd,s}$	[kN]	4.40	8.08	12.80	18.64	34.40	53.92	101.55

### Reduction / increasing resistance factors for edge distance and spacing

Edge distance (tension)

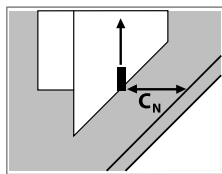

Reduction factors for edge distance  $< C_{cr,N}$  applicable to  $N_{Rd}$  or  $N_{rec}$  for non-cracked concrete from 'Basic Performance' table

[English]: Tabela ważna tylko dla jednej krawędzi  $< c_{cr,N}$  i  $s \geq s_{cr,N}$ . W innym wypadku skorzystać z programu obliczeniowego Rawlplug EasyFix Anchor Calculator.

$c_N$ [m]	M6		M8		M10		M12		M16		M20		M24	
	$h > 1,84h_{min}$	$h_{min}$	$h > 1,84h_{min}$	$h_{min}$	$h > 1,84h_{min}$	$h_{min}$	$h > 1,84h_{min}$	$h_{min}$	$h > 1,84h_{min}$	$h_{min}$	$h > 1,84h_{min}$	$h_{min}$	$h > 1,84h_{min}$	$h_{min}$
30														
40			0,84	0,84										
45			0,90	0,90										
50	1,00	1,00	0,96	0,96	0,78	0,78								
55			1,00	1,00	0,83	0,83								
60					0,88	0,88								
70					0,98	0,98	0,90	0,90						
75					1,00	1,00	0,94	0,94						
90							1,00	1,00	1,00	1,00				
100											1,00	1,00		
200													1,00	1,00

## Design performance data

Edge distance (shear)

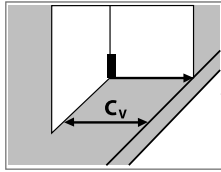

[English]: Współczynniki zwiększające dla odległości od krawędzi  $> c_{min}$  stosowane dla VRd lub Vrec dla betonu niespękanego.

Tables only valid for one edge  $> c_{min}$  and  $s \geq 3c_v$  For other cases use the Rawlplug Anchor Calculator

$c_v$ [m]	M6		M8		M10		M12		M16		M20		M24	
	$h > 1,5c_v$	$h_{min}$	$h > 1,5c_v$	$h_{min}$	$h > 1,5c_v$	$h_{min}$	$h > 1,5c_v$	$h_{min}$	$h > 1,5c_v$	$h_{min}$	$h > 1,5c_v$	$h_{min}$	$h > 1,5c_v$	$h_{min}$
40			0,52	0,52										
45			0,61	0,61										
50	1,00	1,00	0,70	0,70	0,56	0,56								
55			0,79	0,79	0,64	0,64								
60			0,89	0,89	0,71	0,71								
70			1,04	1,04	0,88	0,86	0,52	0,52						
75					0,97	0,91	0,57	0,57						
90					1,14	1,07	0,72	0,72	0,43	0,43				
100					1,21	1,17	0,83	0,79	0,49	0,49	0,33	0,33		
120					1,27	1,27	1,00	0,93	0,62	0,61	0,42	0,42		
140								1,00	0,77	0,69	0,52	0,50		
160									0,91	0,77	0,62	0,56		
180									1,00	0,85	0,72	0,62		
200										0,93	0,83	0,67	0,70	0,60
250										1,00	1,00	0,81	0,94	0,73
300												0,95	1,16	0,85
350												1,00	1,16	0,97
400														1,08
450														1,16

Spacing

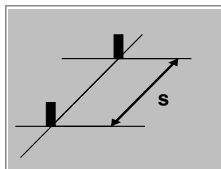

[English]: Tabela ważna tylko dla jednego rozstawu kotew  $< s_{cr,N}$  i  $c \geq c_{cr,N}$  W innym wypadku skorzystać z programu obliczeniowego Rawlplug EasyFic Anchor Calculator.

Reduction factors for spacing  $< s_{cr,N}$  applicable to  $N_{Rd}/V_{Rd}$  or  $N_{rec}/V_{rec}$  for non-cracked concrete from 'Basic Performance' table

$s_N$ [m]	M6		M8		M10		M12		M16		M20		M24	
	$h > 1,84h_{min}$	$h_{min}$	$h > 1,84h_{min}$	$h_{min}$	$h > 1,84h_{min}$	$h_{min}$	$h > 1,84h_{min}$	$h_{min}$	$h > 1,84h_{min}$	$h_{min}$	$h > 1,84h_{min}$	$h_{min}$	$h > 1,84h_{min}$	$h_{min}$
45	0,97	0,97												
50	1,00	1,00	0,83	0,83										
55			0,86	0,86	0,70	0,70								
60			0,88	0,88	0,72	0,72								
70			0,92	0,92	0,76	0,76								
75			0,94	0,94	0,77	0,77	0,81	0,81						
90			1,00	1,00	0,82	0,82	0,85	0,85	0,90	0,90				
100					0,86	0,86	0,88	0,88	0,92	0,92				
120					0,93	0,93	0,94	0,94	0,98	0,98				
140					1,00	1,00	0,99	0,99	1,00	1,00	1,00	1,00		
160							1,00	1,00						
180													1,00	1,00

## Design performance data

Spacing

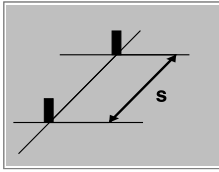

Reduction factors for spacing  $< s_{cr,N}$  applicable to  $N_{Rd}/V_{Rd}$  or  $N_{rec}/V_{rec}$  for non-cracked concrete from 'Basic Performance' table

[English]: Tabela ważna tylko dla jednego rozstawu kotew  $< s_{cr,N}$  i  $c \geq c_{cr,N}$  W innym wypadku skorzystać z programu obliczeniowego Rawlplug EasyFix Anchor Calculator.

$s_v$ [m]	M6		M8		M10		M12		M16		M20		M24	
	$h > 1,5c_v$	$h_{min}$	$h > 1,5c_v$	$h_{min}$	$h > 1,5c_v$	$h_{min}$	$h > 1,5c_v$	$h_{min}$	$h > 1,5c_v$	$h_{min}$	$h > 1,5c_v$	$h_{min}$	$h > 1,5c_v$	$h_{min}$
45	1,00	1,00												
50			0,83	0,83										
55			0,86	0,86	0,70	0,70								
60			0,88	0,88	0,72	0,72								
70			0,92	0,92	0,76	0,76								
75			0,94	0,94	0,77	0,77	1,00	1,00						
90			1,01	1,01	0,82	0,82			0,83	0,79				
100			1,04	1,04	0,86	0,86			0,85	0,80				
120					0,93	0,93			0,89	0,84				
140					1,00	1,00			0,92	0,87	0,74	0,69		
160					1,07	1,07			0,96	0,90	0,76	0,72		
180					1,14	1,14			0,99	0,94	0,79	0,74	0,76	0,71
200					1,21	1,21			1,00	0,97	0,81	0,76	0,78	0,73
250					1,27	1,27				1,00	0,87	0,82	0,83	0,79
300											0,94	0,88	0,89	0,84
350											1,00	0,94	0,94	0,89
400												1,00	1,00	0,94
450													1,05	0,99
500													1,11	1,05
550													1,16	1,10
600														1,15
700														1,16

## Design performance data

Reduced embedment depth

Size			M6	M8	M10	M12	M16	M20	M24
Effective embedment depth	$h_{ef}$	[mm]	22.00	32.00	39.00	48.00	65.00	79.00	97.00
<b>TENSION LOAD</b>									
<b>STEEL FAILURE</b>									
Characteristic resistance	$N_{Rk,s}$	[kN]	9.58	15.80	25.20	37.30	66.10	101.00	180.39
Design resistance $V_{Ms} = 1.4$	$N_{Rd,s}$	[kN]	6.84	11.29	18.00	26.64	47.21	72.14	128.85
<b>PULL-OUT FAILURE; NON-CRACKED CONCRETE C20/25</b>									
Characteristic resistance	$N_{Rk,p}$	[kN]	2.98	6.05	8.87	12.87	19.36	28.05	35.36
Design resistance $V_{Mp} = 2.52$	$N_{Rd,p}$	[kN]	1.18	2.40	3.52	5.11	7.68	11.13	14.03
Increasing factors for $N_{Rd,p}$ - C30/37	$\psi_c$	-	1.00	1.00	1.00	1.00	1.00	1.00	1.00
Increasing factors for $N_{Rd,p}$ - C40/50	$\psi_c$	-	1.00	1.00	1.00	1.00	1.00	1.00	1.00
Increasing factors for $N_{Rd,p}$ - C50/60	$\psi_c$	-	1.00	1.00	1.00	1.00	1.00	1.00	1.00
Spacing	$s_{cr,N}$	[mm]	66.00	96.00	117.00	144.00	195.00	237.00	291.00
Edge distance	$c_{cr,N}$	[mm]	33.00	48.00	59.00	72.00	98.00	119.00	146.00
<b>SHEAR LOAD</b>									
<b>CONCRETE EDGE FAILURE; NON-CRACKED CONCRETE C20/25</b>									
Edge distance	$c_1$	[mm]	45.00	40.00	65.00	100.00	100.00	125.00	160.00
Characteristic resistance for $c_1$	$V_{Rk,c}$	[kN]	5.05	4.70	9.67	18.36	20.04	28.81	42.54
Design resistance $V_{Mc} = 1.8$	$V_{Rd,c}$	[kN]	2.80	2.61	5.37	10.20	11.13	16.00	23.63
<b>CONCRETE PRY-OUT FAILURE; NON-CRACKED CONCRETE C20/25</b>									
	$k$	-	1.00	1.00	1.00	1.00	2.00	2.00	2.00
Characteristic resistance	$V_{Rk,cp}$	[kN]	2.98	6.05	8.87	12.87	38.72	56.10	42.54
Design resistance $V_{Mc} = 2.52$	$V_{Rd,cp}$	[kN]	1.18	2.40	3.52	5.11	15.37	22.26	28.06
<b>STEEL FAILURE</b>									
Characteristic resistance without lever arm	$V_{Rk,s}$	[kN]	5.50	10.10	16.00	23.30	43.00	67.40	126.94
Design resistance $V_{Ms} = 1.25$	$V_{Rd,s}$	[kN]	4.40	8.08	12.80	18.64	34.40	53.92	101.55

### Reduction / increasing resistance factors for edge distance and spacing

Edge distance (tension)

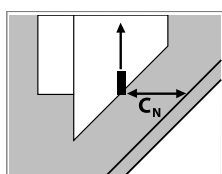

Reduction factors for edge distance  $< C_{cr,N}$  applicable to  $N_{Rd}$  or  $N_{rec}$  for non-cracked concrete from 'Basic Performance' table

[English]: Tabela ważna tylko dla jednej krawędzi  $< c_{cr,N}$  i  $s \geq s_{cr,N}$ . W innym wypadku skorzystać z programu obliczeniowego Rawlplug EasyFix Anchor Calculator.

$c_1$ [m]	M6		M8		M10		M12		M16		M20		M24	
	$h > 1,84h_{min}$	$h_{min}$	$h > 1,84h_{min}$	$h_{min}$	$h > 1,84h_{min}$	$h_{min}$	$h > 1,84h_{min}$	$h_{min}$	$h > 1,84h_{min}$	$h_{min}$	$h > 1,84h_{min}$	$h_{min}$	$h > 1,84h_{min}$	$h_{min}$
40			0,87	0,87										
45	1,00	1,00	0,95	0,95										
50			1,00	1,00										
55														
60														
70					1,00	1,00								
75														
90														
100							1,00	1,00	1,00	1,00				
120														
140											1,00	1,00		
160													1,00	1,00

## Design performance data

Edge distance (shear)

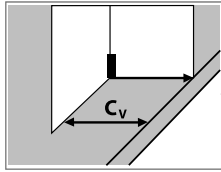

[English]: Współczynniki zwiększające dla odległości od krawędzi  $> c_{min}$  stosowane dla VRd lub Vrec dla betonu niespękanego.

Tables only valid for one edge  $> c_{min}$  and  $s \geq 3c_v$  For other cases use the Rawlplug Anchor Calculator

$c_v$ [m]	M6		M8		M10		M12		M16		M20		M24	
	$h > 1,5c_v$	$h_{min}$	$h > 1,5c_v$	$h_{min}$	$h > 1,5c_v$	$h_{min}$	$h > 1,5c_v$	$h_{min}$	$h > 1,5c_v$	$h_{min}$	$h > 1,5c_v$	$h_{min}$	$h > 1,5c_v$	$h_{min}$
40			0,78	0,78										
45	1,26	1,26	0,91	0,91										
50	1,34	1,34	1,02	1,02										
55	1,42	1,42	1,07	1,07										
60	1,50	1,50	1,12	1,12										
70	1,66	1,66	1,23	1,23	1,06	1,06								
75	1,75	1,75	1,28	1,28	1,10	1,10								
90	1,85	1,85	1,43	1,43	1,22	1,22								
100			1,54	1,54	1,31	1,31	1,15	1,15	0,52	0,48				
120			1,67	1,67	1,47	1,47	1,29	1,29	0,66	0,56				
140					1,64	1,64	1,42	1,42	0,81	0,64	0,60	0,52		
160					1,80	1,80	1,56	1,56	0,97	0,72	0,71	0,58	0,60	0,54
180							1,69	1,69	1,11	0,79	0,83	0,64	0,70	0,60
200							1,81	1,81		0,87	0,96	0,70	0,81	0,65
250										1,06	1,20	0,85	1,09	0,78
300										1,11		0,99	1,37	0,91
350												1,13		1,04
400												1,20		1,17
450														1,30
500														1,37



## Design performance data

### Spacing

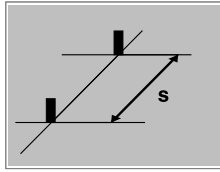

[English]: Tabela ważna tylko dla jednego rozstawu kotew <math>s\_{cr,N}</math> i <math>c \geq c\_{cr,N}</math> W innym wypadku skorzystać z programu obliczeniowego Rawlplug EasyFix Anchor Calculator.

Reduction factors for spacing <math>s\_{cr,N}</math> applicable to <math>N\_{Rd}/V\_{Rd}</math> or <math>N\_{rec}/V\_{rec}</math> for non-cracked concrete from 'Basic Performance' table

$s_{cr,N}$ [m]	M6		M8		M10		M12		M16		M20		M24	
	$h > 1,84h_{min}$	$h_{min}$	$h > 1,84h_{min}$	$h_{min}$	$h > 1,84h_{min}$	$h_{min}$	$h > 1,84h_{min}$	$h_{min}$	$h > 1,84h_{min}$	$h_{min}$	$h > 1,84h_{min}$	$h_{min}$	$h > 1,84h_{min}$	$h_{min}$
40	0,86	0,86												
45	0,90	0,90	0,73	0,73										
50	0,94	0,94	0,76	0,76										
55	0,98	0,98	0,78	0,78	0,71	0,71								
60	1,00	1,00	0,81	0,81	0,73	0,73								
70			0,86	0,86	0,77	0,77								
75			0,89	0,89	0,79	0,79								
90			0,97	0,97	0,85	0,85								
100			1,00	1,00	0,89	0,89	0,82	0,82	0,85	0,85				
120					0,98	0,98	0,89	0,89	0,91	0,91				
140					1,00	1,00	0,95	0,95	0,97	0,97	0,90	0,90		
160							1,00	1,00	1,00	1,00	0,95	0,95	1,00	1,00
180											1,00	1,00		

## Product commercial data

Size	Product Code	Anchor		Quantity [pcs]			Weight [kg]			Bar Codes
		Diameter [mm]	Length [mm]	Box	Outer	Pallet	Box	Outer	Pallet	
M6	R-XPT-HD-06050/10	6	50	100	100	16000	1.32	1.32	241.2	5906675277844
	R-XPT-HD-06085/25	6	85	100	100	16000	2.0	2.0	342.0	5906675277851
	R-XPT-HD-06100/40	6	100	100	100	16000	2.2	2.2	385.2	5906675277868
M8	R-XPT-HD-08050/5	8	50	100	100	16000	2.3	2.3	404.4	5906675277875
	R-XPT-HD-08060/10	8	60	100	100	16000	2.8	2.8	470.0	5906675234007
	R-XPT-HD-08065/15	8	65	100	100	16000	2.9	2.9	490.8	5906675277882
	R-XPT-HD-08075/10	8	75	100	100	16000	3.2	3.2	542.0	5906675234014
	R-XPT-HD-08080/15	8	80	100	100	16000	3.3	3.3	553.2	5906675277899
	R-XPT-HD-08095/30	8	95	100	100	12000	3.8	3.8	482.4	5906675234618
	R-XPT-HD-08115/50	8	115	100	100	16000	4.4	4.4	738.8	5906675234038
	R-XPT-HD-08140/75	8	140	100	100	16000	5.2	5.2	865.2	5906675234045
	R-XPT-HD-10065/5	10	65	50	50	8000	2.4	2.4	414.0	5906675234052
M10	R-XPT-HD-10080/10	10	80	50	50	8000	2.8	2.8	473.2	5906675234069
	R-XPT-HD-10095/25	10	95	50	50	8000	3.2	3.2	534.8	5906675234076
	R-XPT-HD-10115/45	10	115	50	50	6000	3.7	3.7	472.2	5906675234083
	R-XPT-HD-10130/60	10	130	50	50	6000	4.0	4.0	514.8	5906675277905
	R-XPT-HD-10140/70	10	140	50	50	8000	4.4	4.4	728.4	5906675234090
	R-XPT-HD-12080/5	12	80	50	50	8000	4.1	4.1	684.4	5906675234106
M12	R-XPT-HD-12100/5	12	100	50	50	8000	4.8	4.8	799.6	5906675234113
	R-XPT-HD-12120/25	12	120	50	50	6000	5.6	5.6	698.4	5906675277912
	R-XPT-HD-12125/30	12	125	50	50	6000	5.7	5.7	717.0	5906675234625
	R-XPT-HD-12135/40	12	135	50	50	6000	6.3	6.3	781.8	5906675277929
	R-XPT-HD-12150/55	12	150	50	50	4000	6.7	6.7	564.0	5906675234137
	R-XPT-HD-12180/85	12	180	50	50	4000	7.8	7.8	656.0	5906675234144
	R-XPT-HD-12220/125	12	220	50	50	4000	9.3	9.3	775.6	5906675234151
M16	R-XPT-HD-16100/5	16	100	25	25	4000	4.4	4.4	733.2	5906675234168

**Product commercial data**