

R-KER with Sockets

High performance vinylester resin approved for use with internally threaded sockets



Approvals and Reports

- ETA-13/0805



Product information

Features and benefits

- Approved for use in non-cracked concrete (ETAG001 Option 7)
- Allows removal of bolt to leave a re-usable socket in place
- Suitable for use in low temperatures (down to -20°C for winter option) enables use throughout the year
- Winter version can be used in warmer temperatures for faster curing
- Suitable for use in dry and wet substrates as well as holes and substrates covered with water
- Rapid bonding time enables quick execution of works
- Very high load capacity
- Anchor does not generate tensions in the substrate which enables R-KER to be specified where closer edge and spacing distances are required

Applications

- Curtain walling
- Balustrading
- Handrails
- Canopies

Base materials

Approved for use in:

- Non-cracked concrete C20/25-C50/60

Installation guide

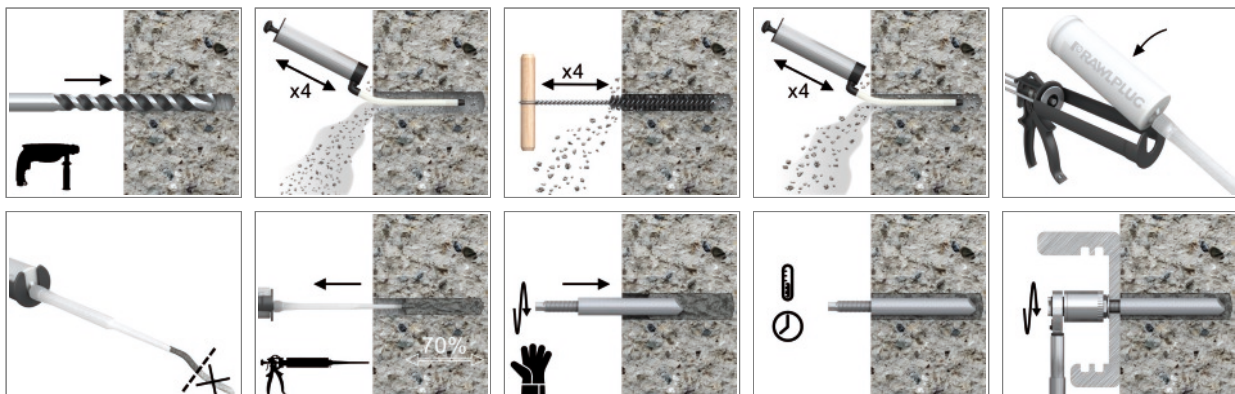

Product information

1. Drill hole to the required diameter and depth for socket size being used.
2. Clean the hole with brush and hand pump at least four times each. It is very important and necessary before installation.
3. Insert cartridge into gun and attach nozzle.
4. Dispense to waste until even colour is obtained.
5. Insert the mixing nozzle to the far end of the hole and inject resin, slowly withdrawing the nozzle as the hole is filled to 2/3 of its depth.
6. Immediately insert the socket, slowly and with slight twisting motion. Remove any excess resin around the hole before it sets and leave it undisturbed until the curing time elapses.
7. Attach fixture and tighten the bolt to the required torque.

Product Code	Resin	Description / Resin Type	Volume
			[ml]
R-KER-280	R-KER	Styrene Free Vinylester Resin	280
R-KER-380			
R-KER-380-W	R-KER-W	Low Temperature (Winter) / Rapid Cure Styrene Free Vinylester Resin	380
R-KER-380-S	R-KER-S	High Temperature (Summer) / Slow Cure Styrene Free Polyester Resin	
R-KER-310	R-KER	Styrene Free Vinylester Resin	310
R-KER-400			400
R-KER-300			300
R-KER-345			345

SOCKETS

Size	Product Code		Anchor			Fixture	
	Steel class 5.8	Steel grade A4	Socket diameter	Length	Internal thread length	Hole diameter	Max. thickness t_{fx} for:
			d	L	l_g	d_f	$h_{nom, std}$
			[mm]	[mm]	[mm]	[mm]	[mm]
M6	R-ITS-Z-06075	R-ITS-A4-06075	10	75	24	7	-
M8	R-ITS-Z-08075	R-ITS-A4-08075	12	75	25	9	-
	R-ITS-Z-08090	R-ITS-A4-08090	12	90	25	9	-
M10	R-ITS-Z-10075	R-ITS-A4-10075	16	75	30	12	-
	R-ITS-Z-10100	R-ITS-A4-10100	16	100	30	12	-
M12	R-ITS-Z-12100	R-ITS-A4-12100	16	100	35	14	-
M16	R-ITS-Z-16125	R-ITS-A4-16125	24	125	50	18	-

Installation data

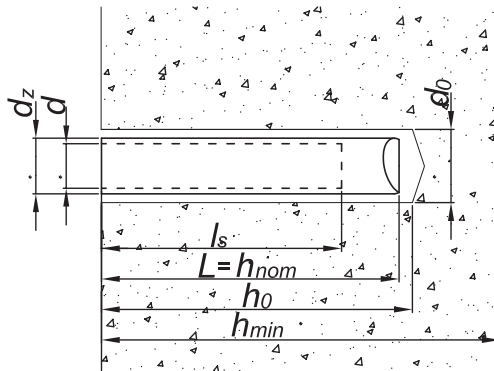

SOCKETS

Size		M6	M8	M10	M12	M16
Thread diameter	d [mm]	6	8	10	12	16
Hole diameter in substrate	d ₀ [mm]	12	14	20	20	28
Hole diameter in fixture	d _f [mm]	7	9	12	14	18
Installation torque	T _{inst} [Nm]	3	5	10	20	40
Thread engagement length	h _s [mm]	6-24	8-25	10-30	12-35	16-50
Min. hole depth in substrate	h ₀ [mm]	h _{ef} + 5	h _{ef} + 5	h _{ef} + 5	h _{ef} + 5	h _{ef} + 5
Min. substrate thickness	h _{min} [mm]	105	105	140	140	181
Min. spacing	s _{min} [mm]	40	40	50	50	63
Min. edge distance	c _{min} [mm]	40	40	50	50	63

Minimum working and curing time

R-KER

Resin temperature	Concrete temperature	Curing time*	Working time
[°C]	[°C]	[min]	[min]
5	-20	-	-
5	-15	-	-
5	-10	-	-
5	-5	240	60
5	0	180	40
5	5	120	20
10	10	80	12
15	15	60	8
20	20	45	5
25	25	30	3
25	30	20	2
25	40	10	0.5

R-KER-W

Resin temperature	Concrete temperature	Curing time*	Working time
[°C]	[°C]	[min]	[min]
5	-20	1440	100
5	-15	960	60
5	-10	480	30
5	-5	240	16
5	0	120	12
5	5	60	8
10	10	45	5
15	15	30	3
20	20	10	2

Installation data

R-KER-S

Resin temperature	Concrete temperature	Curing time*	Working time
[°C]	[°C]	[min]	[min]
5	-20	-	-
5	-15	-	-
5	-10	-	-
5	-5	1440	65
5	0	960	50
5	5	720	35
10	10	480	20
15	15	360	12
20	20	240	9
25	25	180	7
25	30	120	6
25	40	45	4
25	45	35	3
25	50	25	2

Mechanical properties

Size			M6	M8	M10	M12	M16
R-ITS-Z Internally Threaded Sockets							
Nominal ultimate tensile strength - tension	f_{uk}	[N/mm ²]	520	500	500	500	500
Nominal yield strength - tension	f_{yk}	[N/mm ²]	420	400	400	400	400
Cross sectional area - tension	A_s	[mm ²]	20.1	36.6	58	84.3	157
Elastic section modulus	W_{el}	[mm ³]	21.21	50.27	98.17	169.65	402.12
R-ITS-A4 Internally Threaded Sockets							
Nominal ultimate tensile strength - tension	f_{uk}	[N/mm ²]	700	700	700	700	700
Nominal yield strength - tension	f_{yk}	[N/mm ²]	350	350	350	350	350
Cross sectional area - tension	A_s	[mm ²]	20.1	36.6	58	84.3	157
Elastic section modulus	W_{el}	[mm ³]	21.21	50.27	98.17	169.65	402.12
R-STUDS Metric Threaded Rods - Steel Class 5.8							
Characteristic bending resistance	$M_{Rk,s}^0$	[Nm]	8	19	37	65	166
Design bending resistance	M	[Nm]	6	15	30	52	133
Allowable bending resistance	M_{rec}	[Nm]	5	11	21	37	95
R-STUDS Metric Threaded Rods - Steel Class 8.8							
Characteristic bending resistance	$M_{Rk,s}^0$	[Nm]	12	30	60	105	266
Design bending resistance	M	[Nm]	10	24	48	84	213
Allowable bending resistance	M_{rec}	[Nm]	7	17	34	60	152
R-STUDS Metric Threaded Rods - A4							
Characteristic bending resistance	$M_{Rk,s}^0$	[Nm]	11	26	52	92	233
Design bending resistance	M	[Nm]	7	17	34	59	149
Allowable bending resistance	M_{rec}	[Nm]	5	12	24	42	107

Basic performance data

SOCKETS

Performance data for single anchor without influence of edge distance and spacing

Size	M6	M8	M10	M12	M16			
Substrate	Non-cracked concrete							
Effective embedment depth h_{ef} [mm]	75.0	90.0	75.0	100.0	125.0			
MEAN ULTIMATE LOAD								
TENSION LOAD $N_{Ru,m}$								
R-STUDS METRIC THREADED RODS - STEEL CLASS 5.8	[kN]	13	22	22	35	35	50	94
R-STUDS METRIC THREADED RODS - STEEL CLASS 8.8	[kN]	19	35	35	51	55	63	97
R-STUDS METRIC THREADED RODS - A4	[kN]	17	31	31	49	49	63	97
SHEAR LOAD $V_{Ru,m}$								
R-STUDS METRIC THREADED RODS - STEEL CLASS 5.8	[kN]	6	11	11	17	17	25	47
R-STUDS METRIC THREADED RODS - STEEL CLASS 8.8	[kN]	10	18	18	28	28	41	76
R-STUDS METRIC THREADED RODS - A4	[kN]	8	16	16	24	24	35	66
CHARACTERISTIC LOAD								
TENSION LOAD N_{Rk}								
R-STUDS METRIC THREADED RODS - STEEL CLASS 5.8	[kN]	10	18	18	29	29	42	66
R-STUDS METRIC THREADED RODS - STEEL CLASS 8.8	[kN]	16	25	29	33	46	43	66
R-STUDS METRIC THREADED RODS - A4	[kN]	14	25	26	33	41	43	66
SHEAR LOAD V_{Rk}								
R-STUDS METRIC THREADED RODS - STEEL CLASS 5.8	[kN]	5	9	9	14	14	21	39
R-STUDS METRIC THREADED RODS - STEEL CLASS 8.8	[kN]	8	15	15	23	23	34	63
R-STUDS METRIC THREADED RODS - A4	[kN]	7	13	13	20	20	29	55
DESIGN LOAD								
TENSION LOAD N_{Rd}								
R-STUDS METRIC THREADED RODS - STEEL CLASS 5.8	[kN]	7	12	12	18	19	24	37
R-STUDS METRIC THREADED RODS - STEEL CLASS 8.8	[kN]	10	14	17	18	27	24	37
R-STUDS METRIC THREADED RODS - A4	[kN]	7	14	14	18	22	24	37
SHEAR LOAD V_{Rd}								
R-STUDS METRIC THREADED RODS - STEEL CLASS 5.8	[kN]	4	7	7	11	11	17	31
R-STUDS METRIC THREADED RODS - STEEL CLASS 8.8	[kN]	6	12	12	18	18	27	50
R-STUDS METRIC THREADED RODS - A4	[kN]	4	8	8	13	13	19	35
RECOMMENDED LOAD								
TENSION LOAD N_{rec}								
R-STUDS METRIC THREADED RODS - STEEL CLASS 5.8	[kN]	5	9	9	13	14	17	26
R-STUDS METRIC THREADED RODS - STEEL CLASS 8.8	[kN]	7	10	12	13	19	17	26
R-STUDS METRIC THREADED RODS - A4	[kN]	5	10	10	13	16	17	26
SHEAR LOAD V_{rec}								
R-STUDS METRIC THREADED RODS - STEEL CLASS 5.8	[kN]	3	5	5	8	8	12	22
R-STUDS METRIC THREADED RODS - STEEL CLASS 8.8	[kN]	5	9	9	13	13	19	36
R-STUDS METRIC THREADED RODS - A4	[kN]	3	6	6	9	9	13	25

Design performance data

SOCKETS

Size			M6	M8		M10		M12	M16
Effective embedment depth	h_{ef}	[mm]	75.00	75.00	90.00	75.00	100.00	100.00	125.00
TENSION LOAD									
STEEL FAILURE; STEEL CLASS 5.8									
Characteristic resistance	$N_{Rk,s}$	[kN]	10.40	18.00	18.00	29.00	29.00	42.00	78.00
Design resistance $V_{Ms} = 1.5$	$N_{Rd,s}$	[kN]	6.70	12.00	12.00	19.30	19.30	28.00	52.00
STEEL FAILURE; STEEL CLASS 8.8									
Characteristic resistance	$N_{Rk,s}$	[kN]	16.00	29.00	29.00	46.00	46.00	67.00	126.00
Design resistance $V_{Ms} = 1.5$	$N_{Rd,s}$	[kN]	10.70	19.30	19.30	30.70	30.70	44.70	84.00
STEEL FAILURE; STEEL GRADE A4-70									
Characteristic resistance	$N_{Rk,s}$	[kN]	14.00	26.00	26.00	41.00	41.00	59.00	110.00
Design resistance $V_{Ms} = 1.87$	$N_{Rd,s}$	[kN]	7.49	13.90	13.90	21.90	21.90	31.60	58.80
PULL-OUT FAILURE; NON-CRACKED CONCRETE C20/25 (40°C/24°C)									
Characteristic resistance	$N_{Rk,p}$	[kN]	17.70	25.40	30.50	32.80	47.80	42.70	66.00
Design resistance $V_{Mp} = 1.8$	$N_{Rd,p}$	[kN]	9.80	14.10	17.00	18.20	26.50	23.70	36.70
CONCRETE CONE FAILURE; NON-CRACKED CONCRETE C20/25 (40°C/24°C)									
Characteristic resistance	$N_{Rk,c}$	[kN]	-	-	-	32.80	-	-	-
Design resistance	$N_{Rd,c}$	[kN]	-	-	-	18.20	-	-	-
PULL-OUT FAILURE; NON-CRACKED CONCRETE C20/25 (80°C/50°C)									
Characteristic resistance	$N_{Rk,p}$	[kN]	14.10	19.80	23.80	28.30	37.70	32.70	51.80
Design resistance	$N_{Rd,p}$	[kN]	7.90	11.00	13.20	15.70	20.90	18.20	24.70
Increasing factors for $N_{Rd,p}$ - C30/37	Ψ_c	-	1.04	1.04	1.04	1.04	1.04	1.04	1.00
Increasing factors for $N_{Rd,p}$ - C40/50	Ψ_c	-	1.07	1.07	1.07	1.07	1.07	1.07	1.00
Increasing factors for $N_{Rd,p}$ - C50/60	Ψ_c	-	1.09	1.09	1.09	1.09	1.09	1.09	1.00
Spacing	$s_{cr,N}$	[mm]	225.00	225.00	270.00	225.00	300.00	300.00	375.00
Edge distance	$c_{cr,N}$	[mm]	113.00	113.00	135.00	113.00	150.00	150.00	188.00
SHEAR LOAD									
CONCRETE EDGE FAILURE; NON-CRACKED CONCRETE C20/25									
Edge distance	c_1	[mm]	40.00	40.00	45.00	40.00	50.00	50.00	63.00
Characteristic resistance for c_1	$V_{Rk,c}$	[kN]	3.90	4.30	5.07	4.77	6.45	7.06	11.40
Design resistance $V_{Mc} = 1.5$	$V_{Rd,c}$	[kN]	2.60	2.87	3.38	3.18	4.30	4.71	7.59
STEEL FAILURE; STEEL CLASS 5.8									
Characteristic resistance without lever arm	$V_{Rk,s}$	[kN]	5.00	9.00	9.00	14.00	14.00	21.00	39.00
Design resistance $V_{Ms} = 1.25$	$V_{Rd,s}$	[kN]	4.00	7.20	7.20	11.20	11.20	16.80	31.20
STEEL FAILURE; STEEL CLASS 8.8									
Characteristic resistance without lever arm	$V_{Rk,s}$	[kN]	8.00	15.00	15.00	23.00	23.00	34.00	63.00
Design resistance $V_{Ms} = 1.25$	$V_{Rd,s}$	[kN]	6.40	12.00	12.00	18.40	18.40	27.20	50.40
STEEL FAILURE; STEEL GRADE A4-70									
Characteristic resistance without lever arm	$V_{Rk,s}$	[kN]	7.00	13.00	13.00	20.00	20.00	29.00	55.00
Design resistance $V_{Ms} = 1.56$	$V_{Rd,s}$	[kN]	4.49	8.33	8.33	12.80	12.80	18.60	35.30

Design performance data

Reduction / increasing resistance factors for edge distance and spacing

Edge distance (shear)

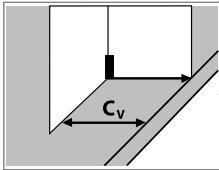

Tables only valid for one edge $>C_{min}$ and $s \geq 3c_v$. For other cases use the Rawlplug Anchor Calculator

Increasing factors for edge distance $>C_{min}$ applicable to $V_{Rd,c}$ for non-cracked concrete from Design Performance table

C_v [mm]	M6	M8	M10	M12	M16
40	1,00	1,00	-	1,00	-
50	1,33	1,33	1,14	1,32	1,00
60	1,69	1,68	1,44	1,66	1,25
65	1,88	1,87	1,60	1,85	1,39
70	2,06	2,05	1,76	2,03	1,52
85	2,67	2,65	2,26	2,61	1,95
90	2,88	2,86	2,44	2,81	2,10
105		3,51	2,98	3,45	2,56

Edge distance (tension)

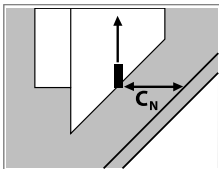

Table only valid for one edge $<C_{cr,N}$ and $S \geq S_{cr,N}$. For other cases use the Rawlplug Anchor Calculator

Reduction factors for edge distance $<C_{cr,N}$ applicable to N_{Rd} or N_{rec} for cracked and non-cracked concrete from 'Basic Performance' table

C_N [mm]	M6	M8	M10	M12	M16
40	0,55	0,55	-	0,55	-
45	0,57	0,57	0,53	0,57	-
50	0,60	0,60	0,56	0,60	0,53
65	0,69	0,69	0,63	0,69	0,59
75	0,75	0,75	0,67	0,75	0,64
85	0,81	0,81	0,72	0,81	0,68
95	0,88	0,88	0,78	0,88	0,73
115	1,00	1,00	0,88	1,00	0,82
135	-	-	1,00	-	0,92
150	-	-	-	-	1,00
170	-	-	-	-	-
190	-	-	-	-	-

Design performance data

Spacing

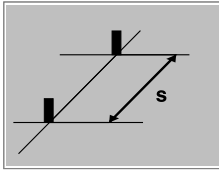

Table only valid for one spacing $< s_{cr,N}$ and $c \geq c_{cr,N}$. For other cases use the Rawlplug Anchor Calculator

Reduction factors for spacing $< s_{cr,N}$ applicable to N_{Rd}/V_{Rd} or N_{rec}/V_{rec} for non-cracked concrete from 'Basic Performance' table

s [mm]	M6	M8	M10	M12	M16
40	0,59	0,59	-	0,59	-
45	0,60	0,60	0,58	0,60	-
50	0,61	0,61	0,59	0,61	0,58
65	0,64	0,64	0,62	0,64	0,61
90	0,70	0,70	0,67	0,70	0,65
120	0,77	0,77	0,72	0,77	0,70
150	0,83	0,83	0,78	0,83	0,75
180	0,90	0,90	0,83	0,90	0,80
210	0,97	0,97	0,89	0,97	0,85
225	1,00	1,00	0,92	1,00	0,88
250	-	-	0,96	-	0,92
270	-	-	1,00	-	0,95
300	-	-	-	1,00	1,00
340	-	-	-	-	0,95
375	-	-	-	-	1,00

Product commercial data

Size	Product Code	Volume [ml]	Quantity [pcs]			Weight [kg]			Bar Codes
			Box	Outer	Pallet	Box	Outer	Pallet	
Ø32	R-KER-280 ¹⁾	280	10	10	840	5.7	5.7	511.4	5906675049663
	R-KER-380 ¹⁾	380	10	10	560	8.2	8.2	486.6	5906675222707
	R-KER-380-W ¹⁾	380	10	10	560	8.2	8.2	486.6	5906675222981
	R-KER-380-S ¹⁾	380	10	10	560	6.5	6.5	391.2	5906675099088
	R-KER-310 ¹⁾	310	10	10	840	6.5	6.5	573.7	5906675251851
	R-KER-400 ¹⁾	400	10	10	560	8.1	8.1	483.8	5906675329444
	R-KER-300 ¹⁾	300	10	10	840	6.3	6.3	559.2	5906675075167
	R-KER-345 ¹⁾	345	10	10	840	7.1	7.1	623.3	5906675291086

¹⁾ ETA-13/0805